

**The United States of America  
in Biblical Prophecy**

**A Warning to the People**

**By  
Norman E. Jones**

**April 10, 2011**

Copyright 2008 Norman E. Jones  
under another Title

**You may copy this book for personal use;  
you may not change any part, and you may not copy it to sell.**



## Acknowledgements

To Whom I am grateful

First I would like to thank Father God, our Lord and Savior Jesus Christ and the Holy Spirit for giving me life, salvation, spiritual gifts and inspiration to write this book. Without them, I am nothing. Without them, this book would not be possible. I love you Lord.

I also want to acknowledge that the Bible, in the original languages, is inerrant. The New American Standard Version Bible, which I study, is the inerrant Word of God in my life. It is the supreme authority in all matters of its history, of faith and human conduct. Thank you God for loving me.

I would like to honor my parents, Stanton W. and Virginia C. Jones for bringing me up in the way I should go; to love and serve God.

I thank Karen, my wife, for putting up with me spending thousands of hours writing. In a way, she has given her life for the cause of Christ by forgoing pleasures and companionship because I was occupied. I love you for believing in God's purposes and in me to fulfill them. Thank you for your effort above and beyond. I know your honor is great in Heaven.

I want to acknowledge the worth of Charles C. Ryrie, for his book, Basic Theology, as a great asset to classifying and denoting the hundreds of facets of God and Christianity. This work has given me an outline, into which, I can insert the explanation of my understanding of God. Thank you for your monumental effort to the cause of Christ.



# The United States of America in Biblical Prophecy

## Table of Contents

Acknowledgements .....	3
Table of Contents .....	5
Preliminary Remarks .....	9
Modern Nations in Biblical Prophecy .....	13
1. Future King? .....	16
2. Succeeding and Concurrent Empires .....	17
3. The “Type” Picture .....	19
Times of the Gentiles Chart .....	20
4. Present World Powers .....	22
The British Lion and American Eagle .....	22
The Russian Bear .....	26
The Arab-African Leopard .....	28
The Ten-Headed European Beast .....	29
5. The End-Time Bear .....	30
6. Revelation 13 Parallel to Daniel 7 .....	31
7. Conservative Expositors View .....	32
The Three Contextual Possibilities .....	33
Possibility 1, Vestiges? .....	34
Possibility 2, The Accepted Fundamental Conservative Position .....	35

# Table of Contents

*cont'd*

Accepted Fundamental Conservative Position problems. . . . .	37
Possibility 3, Similar Empires but not Identical . . . .	39
Increased Strength. . . . .	40
Different National Symbols . . . . .	41
A Summary and Conclusions . . . . .	42
The United States of America; It's Future and Destiny . . . .	45 - 48
George Washington's Vision. . . . .	49 - 54
Warning to the people of the United States of America . . . .	55 - 56
Appendix A, How to Know God Personally, Right Now . . . . .	57 - 62







## Preliminary Remarks

*Personal Testimony, Theology and Generalities*

### I. Personal Testimony

I believe God has been preparing me for this work for most of my life. My parents were members of the Church of Christ. I grew up with four-part harmony congregational singing because the Church didn't believe in instrumental music. The worship quality was far better than today. I loved the singing. It was very uplifting and worshipful.

My christian life started with asking Jesus to be my savior, and being baptized when I was twelve years old at a church camp. I was an ordinary kid and didn't get into much trouble. My first interest in the Bible came in the third year of high school. Our pastor was selling family type Bibles, big ones, and I bought one. I didn't read it all that much but I filled out the family information section. I have kept it all these years. I am now sixty-nine years old.

I went to church through the time I was in the Army but stopped going when I got out and started going to college. It wasn't until 1975 that God started tugging again at my heart strings. I started missing God. And, one Sunday, I realized I had left God, and I became afraid I would die and go to Hell before I rededicated my life. So I ran to the nearest Church of Christ and rededicated. But I was still not born-again. I went to church for a while but my unbelieving wife would not go with me so I went alone.

In September, 1976, when my oldest daughter was four years old, and youngest daughter six months, their mother decided she wanted a divorce from me. I was devastated. I didn't know what to do. I was going to church but God was not very real to me. Some months before, a youth pastor was going around our neighborhood calling on people to talk about God. He talked to me but I was not buying it.

After my wife had divorce papers served, I wondered what to do. I thought I would leave her and the kids, just run to Alaska, where my

brothers lived, and start over with a new life. But I knew I really shouldn't abandon my children, so after two weeks of pondering, I finally decided I needed to stay around and try to make it right with her and the kids.

But when I made that decision to stay, I also was forced to acknowledge that I was a failure. This was my second failed marriage. I felt terrible. It was a Sunday, so I decided to go to the youth pastors church near our house. I talked to the pastor and he agreed to come over that evening.

He came to the house and I told him about what I have told you. He said that before I could make it right with my wife and kids, I needed to make it right with God. I said to him, "What has God got to do with any of this?" He said to me that if I would ask God to forgive my sins, He would forgive me and would manage my life. **God managing my life!** The pastor said *my* responsibility was to do what God said in the Bible, and God would make my life successful by His standards.

That is exactly what I needed; I was a failure, and I needed the God of the universe to manage my life. I asked God to forgive me and to take responsibility for success of my life. That night I was rebaptized, and a tremendous burden was lifted off my back.

I didn't have to worry about managing my life anymore. I didn't have to worry about being a failure anymore. I didn't have to worry about making a living, owning a house, being retired, none of it. It was now God's job to take care of me. It was my job to **be** a man of God. I have sought to be a man of God ever since. I started to be a man of God by studying. I was living alone, and after the divorce, I studied three hours a day, every day, for a year. The youth pastor taught me, one on one, for that year. At 35 years old, I went to the high school bible study that he taught. I learned right along with the youth. My appetite for the Word of God was voracious. My bible has been rebound twice (the one my mentor gave me). Its nearly worn out a third time. I was a failure and I wanted to be different. God had a purpose and a plan for my life all along. I didn't know it then, but I just trusted God to make my life successful by His standards. I began to want to study future prophecy because it interested me. I have discovered some things of value for the future. They can be viewed in this book and on my website, "**www.soul-survival.info**". God has given me talents and the desire to serve Him. As the years went by, I saw His hand greatly on my life. My life has not

been easy but both my daughters have grown up with God in their lives, and both have married christian men who walk with God, and both are raising their children in the nurture and admonition of the Lord. They, serving God, are my greatest joy in life.

Someone before me spoke of how Moses, the son of Pharaoh's daughter, spent the first forty years of his life learning that he was a "somebody," the son of pharaoh's daughter. He spent the second forty years on the backside of the desert, learning he was a "nobody," and the third forty years learning that God could take a "nobody" and make him a "somebody." I feel like how Moses might have felt towards the end of his life. This job is daunting. But God and I are a majority; because He has prepared me for this my whole life. That is why I can write this book. God is with me, and I with Him.

My wife of 22 years Karen, and I, reside in Apache Junction, Arizona, where we attend and serve at Mission Community Church in Gilbert, Arizona.

## **II. Theology**

### **General Theology**

Dr. Charles C. Ryrie's book on "Basic Theology" (B.T. will be a reference to Ryrie's book throughout) is a standard work of some importance among lay people who are not professional theologians. What he says is both foundational and written in a non-technical way. I would like to quote him as follows, page 10:

"The phrase 'sound doctrine,' that Paul (the Apostle) uses, means healthy doctrine (e.g., 2 Tim. 4:3; Titus 1:9). Healthy doctrine or healthy theology is always expected to result in holy living. When Paul prayed for churches, he prayed for an increase in knowledge, for he realized that this would produce holy living (e.g., Phil. 1:9-11; Col. 1:9-10). Healthy theology is expressed not only in creed but in fruitful living, and holy living must be based on healthy theology.

"How theology affects my life or your life is our own personal and individual responsibility. But to conform our lives to the image of Christ is the ultimate goal in studying theology. Yet in the final analysis no book can do that. Only God and you can." Healthy theology is my own goal as well as Dr. Ryrie's.

## **My Theology**

Since I want my opinion to be heard in the christian forum, and since I am unknown, as to what I believe, it seemed prudent to give you some idea of what kind of christianity I embrace.

I can say that I tend to have a Arminian point of view. The points on which I differ with Arminianism is significant but generally compatible. The only exceptions to that might be the issues which I address. That would be the part which I personally contribute.

I will endeavor, as I write, to note any significant differences. Other than this, you can depend on my being orthodox, in the sense of balanced, like Dr. Ryrie. I hope you will agree.

I will do my best, with the Holy Spirit's leading, to *honor* God, and uphold His reputation. I believe in "Managed Cooperation Theology".

Quite simply, God manages; man cooperates.

It is God that manages my life, and should manage all christian's lives. This idea is expressed by John MacArthur when he talks about making Jesus "Lord" of your life. Another way to put it; follow Jesus as a disciple.

## **VI. Bible Usage and Quotes**

All quotes and usage will be from the New American Standard Version, The Lockman Foundation, 1975.

## **VII. Other Writing**

See my complete writing on-line at:

**[www.soulsurvival.info](http://www.soulsurvival.info)**

Other books coming soon:

The Coming Great Tribulation: the Order of Judgement Events

## Modern Nations in Biblical Prophecy

*"But as for you Daniel, conceal these words and seal up the book until the end of time; many will go back and forth, and knowledge will increase."*

*Daniel 12:4*

Many Spirit filled people seem to believe the rapture of the church, the Tribulation and Second Coming are near. However, most are unsure how the current world powers fit into the Biblical prophetic picture. How do the United States, Russia, the Middle Eastern countries, Europe and Red China fit in?

Doesn't it seem reasonable that if we are close to the end, there has to be a transition from what now is, to what is prophesied to be? Shouldn't God have something to say about world affairs near the end?

The Bible teaches that near the end of time, just before the second coming of Christ, there will exist four world class nation-empires. Three of which are taken over by the fourth that soon crushes all the other three. After seven years of the Great Tribulation, Jesus comes back to Earth and takes back control of the Earth, after the battle of Armageddon. This is outlined in the book of Daniel, Revelation and other places. This is what God has prophesied will happen.

One of the ways we know that this is how the end occurs is given in Daniel 2 where King Nebuchadnezzar has a statue dream. The statue in his dream has a head of gold, chest and arms of silver, belly and thighs of brass, legs of iron, and feet of iron and clay. As the king is watching, a rock, not cut with hands, hits the statue on its feet and the statue comes crashing down being dashed to powder and is blown away by the wind. The rock then fills the whole Earth.

Some say it is ancient empires as is defined in Daniel chapter eight.

Those who believe it is ancient empires also believe that Daniel chapter seven is describing ancient empires.

I believe it is ancient empires that are defined in Daniel, Chapter Eight. The picture is of a ram with two horns butting westward, northward and southward. He did as he pleased and magnified himself and no one could stand before him. Later, a goat came from the west, flying over the ground, with a large horn between his eyes. The goat shattered the horns of the ram and trampled him into the ground. The goat magnified himself but his large horn was replaced by four smaller horns. One of the horns magnified himself greatly like God, invaded Israel, desecrated the temple and stopped the regular sacrifice. Later, the temple was cleansed and sacrifices resumed. Most conservative expositors, including me, believe Chapter Eight describes ancient empires.

I believe it is modern empires that are defined in Daniel Chapter Seven. The following paragraph gives you a synopsis of what nation-empires exist now.

- \* The United States of America is a real power in the world but in decline.
- \* The Confederation of Independent States (CIS = Russia) a world class power but also is in decline.
- \* The Arab / Africa coalition of countries (the nation of Islam); a weaker but none-the-less world class empire.
- \* The European Economic Conference (EEC), the multinational confederation of European nations. These together make a very powerful empire.
- \* The Chinese, Japanese and other Asian nations make a fifth empire which does not come into play, in my opinion, until the latter part of the Tribulation time. These are all the significant world class powers existing now.

So how do we get from the current world political situation just described, to that which is described in prophecy? Is this confusion present because the Bible is silent on the End Time players who are on the world stage? Did God choose to not tell us, or has something been overlooked? I believe the latter, and I suggest Daniel Chapter Seven holds the interpretative key.

I see the following new observations in the description of the four beasts of Daniel 7:1-7. The first is like a lion with eagle's wings which I see as the United States. The next is like a bear which represents the

Commonwealth of Independent States (CIS); formerly the USSR. The third is described as a leopard with four wings; symbolizing the Arab/Africa coalition. The fourth is described as dreadful, terrifying and extremely strong with large iron teeth representing the ten nation European Economic Conference (EEC) and its succeeding forms. But first, let's get some more background.

A key situation is given in Daniel 2:31-35, where King Nebuchadnezzar has a dream of a poly metallic statue. The statue had a head of gold, chest and arms of silver, belly and thighs of bronze, legs of iron, and feet of iron and clay. He continued looking until a stone, not cut with hands, struck the statue on its feet. The statue came crashing down, was crushed to powder, and blew away with the wind. Then the stone filled the whole earth.

Most everyone agrees that the statue represents some of the world class empires during the "times of the gentiles" from the existence of Babylon to the second coming of Christ. Some of the empires existing in between are left out. Germany during world war II might be an example. The point seems to be the start and finish of the age. Daniel 2:38 says King Nebuchadnezzar is the head of gold. But we also see and agree that the "Rock" is Jesus at the second coming.

**Who the vision of the statue represents at the end time, and who the vision of Chapter Seven is talking about is the subject of this book.**

I see seven reasons why Daniel Chapter Seven applies to modern nation-empires:

**(1) Future King?** In Daniel Chapter Two, verse 38, King Nebuchadnezzar is named as the head of gold of the poly metallic statue which was a part of his dream. But since the king was already dead when Daniel wrote chapter seven, he could not possibly be one of four future kings mentioned in chapter seven, verse seventeen. This is a show-stopper.

**(2) Succeeding and Concurrent Empires.** The four ancient empires, listed above, never existed concurrently. They only existed succeeding each other. The four end time empires all must exist concurrently for Jesus to crush them "all at the same time", and take control of the world. This means ancient empires cannot be the gold, silver, etc. which are present at the end time. The gold, silver, etc. necessarily must relate to empires other than ancient empires; namely the modern empires.

This also is a show-stopper.

**(3) Ancient empires, now impotent, cannot be world class powers in the 21st century.** But many times in scripture God speaks through a “type” picture. The “type” I see here, answers the time problems of the popular conservative view. It gives more truth about Daniel Chapters 2,7, and 8 than is now accepted, and it decodes the figurative language of those chapters. The “type” picture is illustrated in the chart on page 17.

**(4) The scripture closely relates to the existing world class nation-empires.** The "Lion/Eagle", "Bear", "Leopard" and "Ten-headed Beast" symbols relate closely with the present world powers; bringing life to the scriptures in the 21st century.

**(5) Russia is known to be in prophetic events.** The C.I.S. (USSR), a current world power, whose national symbol is the "Bear", is known to be involved in end time events as evidenced in Ezekiel 38 and 39.

**(6) Revelation 13 relates to Daniel 7.** Revelation Chapter 13, which is known to be prophetic, pictures nations **after** take-over by Antichrist. But Daniel Chapter Seven pictures the same nations **before** take-over by Antichrist (4th Beast). Thus, they are linked and in-play in 2011.

**(7) Conservative expositors viewpoint has disqualifying flaws.** We will look at some of those problems. Nebuchadnezzar is named a “head of gold” but he doesn’t exist in the 21st century. Therefore, there must be some other “head of gold” that does exist in the 21st century; which can be crushed by Jesus. This dilemma defines why conservative expositors have trouble understanding this Chapter Seven passage. I will discuss the problems of their view, and what needs to be different.

Next is the first reason I believe this view is correct.

## **1. Future King?**

This problem is time related. In Chapter Two, Daniel tells King Nebuchadnezzar that he is the "head of gold", verse 38. Thus linking the gold of the statue with the king of Babylon. And conservative expositors link Babylon with the first beast of Chapter Seven.

In my view, Babylon cannot be the first beast of Chapter Seven. Chapter Seven, verse 17 reads, "These great beasts, which are four in



number, are four kings who will arise from the earth." Since Nebuchadnezzar died at least four years before Daniel wrote Chapter Seven, he cannot possibly be one of four future kings. Therefore, if Nebuchadnezzar cannot be linked with one of four future kings in Chapter Seven, then it is not very likely Daniel is talking about Babylon in Chapter Seven.

You might ask, couldn't Babylon be rebuilt? It doesn't seem possible according to Jeremiah 25:12, 50:39-40, and 51:62. I just cannot see Nebuchadnezzar as possibly being the end time head of gold. However, he can be an "anti-type" of the head of gold. This is a fatal flaw. It is not intellectually honest to portray King Nebuchadnezzar, who has already died, as one of four future kings.

## 2. Succeeding and Concurrent Empires

In Daniel chapter two, there are verses which suggest that the empires represented by the poly-metallic statue succeed each other. In verses 38-40, we see succeeding empires. Daniel is talking to King Nebuchadnezzar in verse 38.

"You are the head of gold.

39 "And after you there will arise another kingdom inferior to you, then another third kingdom of bronze, which will rule over all the earth.

40 "Then there will be a fourth kingdom as strong as iron;...."

The words "after you" (Aramaic: Athar, "to follow") and "then" (Aramaic: Edayin, "then") imply that one succeeds the other.

History since has shown that indeed the Medo-Persian empire overthrew Babylon. Greece, under Alexander the Great, overthrew the Medes and Persians. After Alexander's empire was divided among his four generals, the Romans took world control from them. Verse 40 goes on to talk about the Roman empire.

These empires existed separately and in no case did more than two exist together at any given time with significant world class status. That means these ancient empires succeeded one another as the verses say. It also means the four ancient empires **did not** all exist together concurrently. The ancient empires not existing together concurrently disallows

them from being the representatives of empires at the end time second coming.

This is because chapter two, verses 34-35, demand that the nation-empires existing at the second coming all be present concurrently such that they all can be crushed at the same time.

“You continued looking until a stone was cut out without hands; and it struck the statue on its feet of iron and clay, and crushed them. Then the iron, the clay, the bronze, the silver and the gold were crushed all at the same time, and became like chaff from the summer threshing floors; and the wind carried them away so that not a trace of them was found. But the stone that struck the statue became a great mountain and filled the whole earth.”

As we just discussed, they all exist at the same time unless you spiritualize the words "at the same time". This thought is further reiterated in Verse 45:

“Inasmuch as you saw that a stone was cut out of the mountain without hands and it crushed the iron, the bronze, the clay, the silver and the gold, the great God has made known to the king what will take place in the future; so the dream is true, and its interpretation is trustworthy.”

This means there are four nation-empires, as represented by the poly-metallic statue, which exist concurrently with each other. They must be present for Jesus to crush at the second coming.

To summarize, we see Chapter Two having verses that imply the statue represents both succeeding and concurrent empires. In verses 38-40 the empires succeed each other. Verses 34-35 and 44-45 imply the empires exist at the same time. It is impossible for a single set of empires to be both succeeding and concurrent. **Therefore, there must be two sets of empires involved.** This means ancient empires **cannot** be represented at the end time coming of Jesus. This is a fatal flaw for those that believe ancient empires are represented in Daniel Chapter Seven. Daniel Chapter Seven represents nation-empires at the second coming.

The literal explanation, in my opinion, is the gold, silver, etc. represent in one case Babylon, Medo-Persia, etc. and in the other case concurrent empires of USA, CIS, Arab / Africa coalition and EEC. Thus, Daniel Chapter Two implies two sets of future empires; the ancient and

the modern.

### 3. The Type Picture

We read in Daniel Two how Nebuchadnezzar, King of Babylon, dreamed one night of a great statue. The statue had a head of gold, chest of silver, belly and thighs of brass, legs of iron, and feet of iron and clay. As the king watched, a rock not cut with hands struck the statue on its feet. The statue collapsed and the rock crushed it to powder which blew away with the wind. Then the rock grew until it filled the whole earth.

Daniel interpreted the dream for the king which goes as follows:<sup>1</sup> He said Nebuchadnezzar, was the head of gold. Then another inferior kingdom of silver would come, and yet a third kingdom of bronze would rule over the earth. Then a fourth empire of iron which would be strongest of all. And after a time, the iron would mix with clay to form the feet. The feet would be strong but brittle. Then during the days of the iron and clay empire, the God of Heaven (Jesus Christ) would set up His kingdom on earth. That kingdom would crush all others and expand its influence over the whole world.

Conservative expositors believe the four ancient empires represent all the world class empires since Nebuchadnezzar of Babylon. I am also convinced the great statue dream and interpretation in Chapter Two represent all of the world class empires (Times of the Gentiles) as is the popular conservative view.

I would like to point out, again, that modern countries represented by the Gold, Silver, etc. must be present at the Second Coming of Christ. This is because Daniel 2:35, 45 **requires** the Gold, Silver, etc. be crushed "at the same time" by the "Rock" at the Second Coming.

However, we also read verses 38-41 which imply the ancient empires are represented by the Gold, Silver, etc. So how can ancient empires be present at the second coming, and us still offer a literal explanation?

I believe the answer is that Daniel 2 has a double fulfillment. I observe that the visions of Daniel Chapters Eight and Seven explain the conflict between verses which imply succeeding empires and concurrent empires. Chapter Eight has its fulfillment in ancient history, and Chapter

---

1. Daniel 2:37-45 New American Standard Bible.

## The Times of the Gentiles

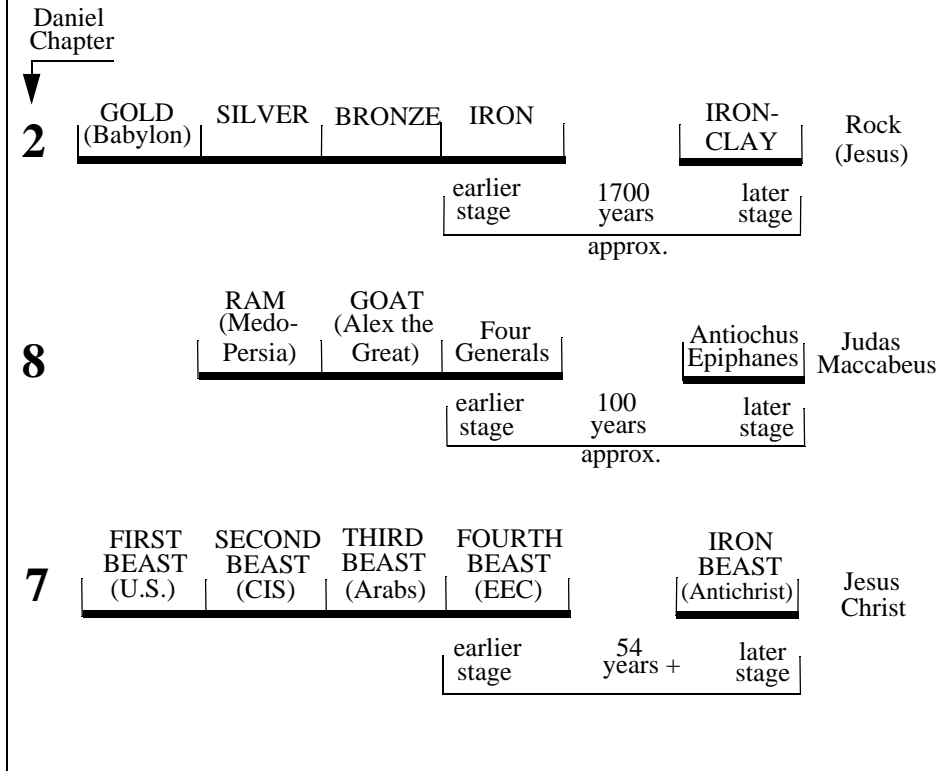

Seven has its fulfillment in modern history. The two together fulfill the vision of Chapter Two.

In Chapter Eight, Daniel relates the vision of the ram and goat followed by the interpretation. According to conservative scholars, the vision goes like this: A ram (Medo-Persia) goes about butting this way and that way (making war) until he runs into a one-horned goat flying through the air (Greece, under Alexander the Great). The goat battered the ram until he was trampled into the ground. The male goat then magnified himself but soon his horn (figurative term for power) was broken.

Four other horns rose up in place of the one-horned male goat (Alexander's four generals). From one of the four horns arose a small horn which grew large toward the south, the east and the beautiful land

(Israel). It removed the regular sacrifice, and for 2300 evenings and mornings the Holy Place was unclean. At the end of that time, the Holy Place was restored. The fundamental conservative interpretation follows.

At the beginning of this vision, Babylon has fallen and Nebuchadnezzar has already died. The scripture now describes the Medo-Persian (ram) and Greek empires (goat). Chapter Eight, verses 21 and 22 relate what turns out to be the empire of Alexander the Great (goat) and his four successors.<sup>2</sup> The four generals, Cassander, Ptolomy, Lysimachus and Seleucus split the territory among themselves.

They and their descendents ruled for some 150 years as a fourth divided empire. Then, from the lineage of General Seleucus, came one Antiochus IV, Epiphanes, who took control of Ptolomy's territory plus his own Selucid Empire.

The other two territories fell to the up coming Roman Empire. Antiochus invaded Palestine, persecuted the Jews, desecrated the Temple and eventually got driven out by one Judas Maccabeus.

Antiochus, this "antichrist", stayed in power for a precise period. Quoting M.R. DeHaan,

"From the time the temple was desecrated and Antiochus slaughtered a swine upon the Altar in Jerusalem, until the time of the deliverance of Jerusalem under Judas Maccabeus was exactly 2300 days."<sup>3</sup>

This fulfills the prophecy of Chapter 8:14-26.

To sum up Daniel Chapter Eight, we see three empires; Babylon (understood as coming previously), Medo-Persia (ram), and Greece (goat). The third is divided; Alexander's empire goes to his four generals. The four generals and their descendents formed a fourth divided empire. Now this fourth empire changed form by the hand of Antiochus and the Romans.

Antiochus persecuted the Jews as a "type" of antichrist, and he was soon driven out by Judas Maccabeus; a "type" of Jesus at His Second Coming. Thus, we see a "type" picture of the end time coming of Jesus in power and great glory which the Jews dreamed of at His First Coming.

---

2. "Daniel - Key To Prophetic Revelation", p.197, John F. Walvoord, Chicago, Illinois: Moody Press, 1971.

3. "Daniel - The Prophet", p.230, M.R. DeHaan, Grand Rapids, Michigan: Cindering Publishing House, 1947.

Chapter Seven, Verses 1-7, offers a similar setting to Chapter Eight except I see it in a modern day setting. We see three beasts (nations) the U.S., C.I.S., Arab/Africa alliance arise from the sea (gentile world), who is trampled by a fourth empire of a multiple nature (European Economic Community), from which the 20th Century Antichrist comes. He desecrates the Jewish Temple (not built yet), and after a precise period of time, Jesus, “the rock not cut with hands”, establishes His kingdom on earth.

The precise period is given in Daniel Chapter 12. Turning to verses 11-12, we read, "and from the time that the regular sacrifice is abolished, and the Abomination of Desolation is set up (happens), there will be 1290 days." Verse 12, “How blessed is he who keeps waiting and attains to the 1335 days!” I take this to mean there will be 1335 days between the end of sacrifices and the "blessed day" (Second Coming). If this is the correct interpretation of this passage, then we see a similar picture to Chapter Eight in its entirety.

The popular conservative view scholars suggest empires represented by the head of gold, chest of silver, belly and thighs of bronze and legs of iron, existed in ancient history. They also say nations represented by the feet of iron/clay will exist in the future (to 2011). I fully agree. This duality is easily explained with the concept of the repeating “type” picture.

The statue image of Chapter Two is seen stretching from Babylon to the Second Coming. In Chapter Eight, we see the ancient kingdoms represented in a story which is a “type” of the end time world ruler. In Chapter Seven, we see the modern kingdoms represented in a story which is also a “type” of the end time world ruler. Between the two chapters, we see the overall Chapter Two picture fulfilled. See the chart on page 17. I suggest it is necessarily fulfilled by Chapters Eight and Seven because the verses in Chapter Two demand the gold, silver, etc. be present for the Rock to crush at the Second Coming. I cannot see any other reasonable explanation which fits **all** the facts.

## **4. Present World Powers**

### **The British Lion and American Eagle**

Now, we want to look at the fourth reason this interpretation applies to

Daniel Seven. It is because Daniel's descriptions closely resemble the major empires present in the world today!

In Chapter Seven, verse four, Daniel paints the first beast as being, “like a lion and having the wings of an eagle.” I observe that the United States, one of the major world powers, could easily be described as a lion with eagles wings. We had our origins in Great Britain, whose national symbol is the lion, and we are like them in language, custom, government and, most important, religion. We are presently allied with them through NATO.

How about the fact that the eagle is our national symbol? Our ICBM's and Air force are a primary power in the world today. The threat of nuclear war between the U.S. and the C.I.S. is the subject of much wonder at what fate lies in wait for this world. Daniel's next sentence comments on the fate of the first beast.

“I kept looking until its wings were plucked,...” Looking at what *could* happen. If you look from a top view, isn't it strange that empty missile silos resemble the holes left in a bird's wing after plucking the feathers? The holes in the ground look similar to the holes left in a birds wing! Without feathers, can a bird fly? Since our ultimate power lies in our missiles, if they are used or destroyed in an exchange, we would be empty of world power. Our “wings” would be “plucked.”

The other major strength we possess is our industrial capacity. Our ability to produce is tied closely to the economic structure. Our economic structure is so well balanced that if part of our industrial capacity was blown away in a missile exchange chaos would result. Thus, our “wings” would be “plucked”.

Daniel goes on to say: “and it was lifted up from the ground and made to stand on two feet like a man; a human mind was given to it”. Remember, this is a “beast” being referred to here. God's use of the word “beast”, as I see it, denotes the degeneration of man, as God would have him to be, to something more base in nature and character.<sup>4</sup>

If someone were to commit a filthy immoral act, we might call them an “animal”. And that is what God means by a beast. The United States is a beast, as I say in the warning section of this book, because of her gross national sins.

God's definition of a “beast” is aptly described in Daniel, Chapter

---

4. .II Peter 2:12

Four. King Nebuchadnezzar exalted himself above God; and to teach him a lesson, God took away his power and gave him the mind of a beast (verse 16). Seven years later, the king recognized God as sovereign, and that it is He who bestows power on whomever He wills (Verse 34-35). So it will be with the U.S. God will allow the United States to be invaded and our world power taken away. But there is hope!

When King Nebuchadnezzar repented, his mind was returned to him (verse 34). And so I believe it will be with the United States of America. When our “wings” are “plucked”, so shall we begin to see that we again need God, and by the end of the seven years of tribulation, so shall we repent as a nation to be “stood up on two feet like a man; a human mind also being given to it” (Daniel 7:4). The action of humbling ourselves before God will cause Him to see the remnant people of the nation as men and not beasts. Thus the Lion / Eagle symbol is appropriate. Therefore, I see the United States mentioned in scripture.

If you think this connection between the U.S. and the Bible is unusual, then you will really think it unusual that George Washington, the father of our country, had a vision which said basically the same thing! You can read about this in the chapter marked George Washington’s vision.

As we said right up front, shouldn't God have something to say about the U.S. if we are involved at the end time? Most conservative scholars do not interpret scripture as relating to modern nations except maybe the C.I.S. relating to Ezekiel 38-39. However, I would like you to consider the following Biblical and historical evidence.

Ezekiel 27 makes reference to Tarshish (Tyre) trading manufactured goods to others for raw materials. In Verse 3, they are called “... merchant of the peoples to many coastlands,....” We see similar statements in Verses 15 and 25. These references open the possibility that Indians of North America were trading with the Merchants of Tarshish. This possibility becomes a probability with the following.

According to Dr. William McBirnie, the prophet Ezekiel alludes to our presence (young lions) in the 38th Chapter of his book:

““The Merchants' (traders of nations who were settled by the traders of Tarshish) "with all its young lions...” (Vs. 13). This may seem to be a faint reference and difficult of (sic) explanation. Far from it! The sea traders of Tarshish were Phoenicians of whom Ezekiel wrote extensively in Chapters 27 and 28. They



have now been proven by recent discoveries to have been not only traders based in Spain, but also to have been extensive colonizers. In brief, the Phoenicians, based in Tarshish, Spain - were the main colonizers and civilizers of all of the Atlantic nations of Western Europe! The phrase 'young lions' in the original Hebrew means 'cubs' or offspring; i.e., colonies. But there is much more. Dr. Barry Fell, of Harvard, has conclusively identified the North American Continent as also having been settled by these same Tarshish-based phoenicians at least 400 Years before Ezekiel wrote. Dr. Fell's book, 'America, B.C.' which was condensed in the Reader's Digest, February 1977, (sic) demonstrates the extensive Phoenician settlement in various parts of what is now the United States!"<sup>5</sup>

Dr. Fell comments from his own book.<sup>6</sup>

"By the eighth century B.C. a group of Syrian colonists had settled the lower reaches of the valley of the Guadalquivir River in Andalusia, southwestern Spain, where they were engaged in trading for metals mined by the natives, who seem to have been mainly Basques. Eventually invading bands of Celts in ever-increasing numbers came down from the north, and by 500 B.C. they had overrun the whole region. Thereafter we hear no more of Phoenicians in this part of Andalusia. Now, however, we have found their inscriptions in America.

"The city built by people in Spain was called Tarshish, and it is referred to by that name in the Old Testament. The Greeks called the city Tartessos, and from this name comes the word Tartessian, used by epigraphers (people who study inscriptions) to describe the special script and dialect employed by the men of Tarshish. The alphabet has been deciphered in part by Spanish epigraphers, and most of the residual letters have now been assigned their phonetic values as a result of the discovery of Tartessian inscriptions in Central and North America. This language can now be read with relative ease, for it proves to be no more

---

5. "The Shape of the Future in the Middle East!", pp.19-20, Glenda, CA: Community Churches of America, 1981.

6. "America B.C.", pp. 93, 98, 100-101, Barry Fell, New York, N.Y.: The New York Times Book Co., 1977.

than a dialectal variant of Phoenician. In fact, one wonders why the Tartessians bothered to devise their own script, seeing they could equally well have employed the script of Phoenicia itself.

“The first Tartessian inscription discovered in America is engraved on a rock on the seashore of Mount Hope Bay, Bristol, Rhode Island. In 1780 it was described and recorded by Ezra Stiles, who later became president of Yale College.

“Under the outline carving of a hull appears a single line of Tartessian Punic, reading from right to left, to yield: *VOYAGERS FROM TARSHISH THIS STONE PROCLAIMS*. The script cannot of itself be accurately dated, but a likely estimate would perhaps be about 700 or 600 B.C. The voyagers were probably not explorers but rather merchants trading with the New England Celts who, by that date, would already be well established fur trappers, and very likely also mining precious metals on those sites where ancient workings have been discovered.

“The periodic arrival of Phoenician ships on the New England coast is attested by the Ogam inscription of Monhegan Island, off the coast of Maine (page 58). It is obvious that the flat-topped rocky islet would not have been set aside for the loading and unloading of Phoenician ships were they not regular visitors to America, with a predictable timetable of ports of arrival and departure at expected dates. It is also clear from the fact that the Monhegan inscription is given in the old Goidelic tongue of the New England Celts, that it was primarily intended as a notification for native American Celts who had goods for sale or exchange, to inform them where to bring their merchandise in order to be sure of meeting with customers from Phoenicia.”

This shows Biblical and historical evidence that the United States is alluded to in scripture.

### **The Russian Bear**

Daniel 7:5a. “And behold, another beast, a second one, resembling a bear.”

Would you care to guess what country is second most powerful in the world today whose national symbol is the bear? It doesn't take much deductive power to see that his initials are C.I.S. All you have to do is

look at the “Bear” on the cover of Time Magazine, January 15, 1979 issue.

“And it was raised up on one side,...”

This connotes a position taken by an animal ready to attack. The raised paw is ready to slap the terrorized victim. The C.I.S. is responsible for much of the terrorism in the world today. Can Iraq, Jordan, Lebanon, Syria, Egypt and Israel be more than lambs for the Russian Bear to crush?

“And three ribs were in its mouth between its teeth; and thus they said to it, ‘Arise, devour much meat!’”

I perceive the word “meat” as figuratively used to mean territory or countries. We see this idea confirmed in Ezekiel 38 and 39 where Russia attacks Israel. In Isaiah 19:23-25, a description is given of a triad of countries at the center of the world, blessed by God.

“In that day there will be a highway from Egypt to Assyria, and the Assyrians will come into Egypt and the Egyptians into Assyria, and the Egyptians will worship with the Assyrians.

(24) In that day, Israel will be the third party with Egypt and Assyria, a blessing in the midst of the earth,

(25) whom the Lord of hosts has blessed, saying, 'Blessed is Egypt My people, and Assyria the work of My hands, and Israel My inheritance.’”

Has this prophecy been fulfilled? Quoting Halley's Bible Handbook, p.295:

“At the time of Christ's appearance the Hebrew nation was composed of three main sections, with connecting highways: Palestinian, Egyptian and Mesopotamian: making Israel to be a sort of three fold nation.”

Do you see the beautiful picture? If this fulfillment is a “type” word picture, then very possibly a treaty could bring these same countries together again. Is not such a treaty the wish of most Middle Eastern people at this moment, and that which is prophesied in Daniel 9:27 as being seven years long? We read that the Tribulation will occur during this period. Don't we also read in Ezekiel 38 and 39 that the C.I.S (Bear) will invade Israel and the Middle East?

The bear not only wants to devour Israel and Egypt but Assyria also;

comprising the modern countries of Jordan, Syria, Lebanon and Iraq. Already Syria, Lebanon and Iraq are under the domination of C.I.S. How descriptive a picture are the three ribs when you think of them as the highways connecting the several countries which they do to this day. Praise God for what seems to be His wonderful engineering of the Holy Scriptures!

Since Ezekiel describes the invasion of Israel and it has not happened yet, and if the Isaiah passage is a "type," then we can conclude the description in Daniel 7:5 (bear devouring something) is yet future and therefore is not in history.

If the above statements do show the "bear" of Chapter Seven to be the modern nation of the C.I.S., then we have shown one more reason why Daniel Seven is a description of modern empires.

### **The Arab-African Leopard**

As we continue to read Daniel Seven, we note a third kingdom. Verse Six, "After this I kept looking, and behold, another one (beast), like a leopard,..." God is so accurate in His prophecy and clear in His descriptions!

What third world countries are symbolized by the leopard? Western and Asian civilization dominate the world today but Africa is fast becoming a factor in world affairs. Several heads of state wear leopard skin as a part of their uniform of royal office. Among them are: Mobutu of Zaire, Jomo Kenyatta of Kenya and former Emperor Haile Salassi of Ethiopia. I understand King Faisal of Saudi Arabia has several leopards on leashes which accompany him at royal functions. These are all symbols of Arab / African identity.

Daniel goes on to say in verse six; "... which had on its back four wings of a bird; the beast also had four heads, and dominion was given to it."

According to Unger's Bible Dictionary, "wings" refers to defences or protection. Since it is natural for a bird to have two wings, it appears the protection comes from two sources.

Four heads refers, as we have seen before, to four heads of state. These represent four nations which are in some kind of union. Ezekiel, in Chapter 38, mentions Ethiopia and Put (Somalia) as African nations involved in end time events. There is a second passage where these two nations are mentioned with other nations in some kind of union, and all

four are involved in last day events.

In Ezekiel 30:3-5, we read a passage confirming Daniel 7:6.

"For the day is near, Even the day of the Lord is near, it will be a day of clouds, A time of doom for the nations.

"And a sword will come upon Egypt, And anguish will be in Ethiopia, When the slain fall in Egypt, They take away her wealth, And her foundations are torn down.

"Ethiopia, Put (Somalia), Lud (Libya)<sup>7</sup> all Arabia, that is in league will fall with them by the sword."

I believe these four nations, Ethiopia, Somalia, Libya and Egypt are the four heads of Daniel 7:6.

### **The Ten-Headed European Beast**

We are still looking at how the present world powers fit the Daniel passage. Now let's examine the nature of the fourth beast destined to produce the "real" Antichrist.

"After this I kept looking in the night visions, and behold, a fourth beast, dreadful and extremely strong; and it had large iron teeth."

We see the prediction of a world class power coming into being with conquest in mind.

"It devoured and crushed, and trampled down the remainder with its feet;..."

Reference is made to controlling the previous three empires which is in effect the rest of the world. This may not include China and some of Asia.

"... and it was different from all the beasts that were before it, and it had ten horns."

The ten horns mean ten nations band together to form one empire. Daniel Chapter Two originates this thought in the picture of the ten toes. On interpreting Chapter Seven, Mr. Walvoord says,

"Premillennialists offer a third view, providing literal fulfillment: ten actual kingdoms will exist simultaneously in the future consummation."<sup>8</sup>

---

7. "Who's Who in the Bible", p.253, Comma and Brawnier, New York, N.Y.:Bonanza Books, 1980.

We observe this happening before our eyes when Greece became the tenth nation of the EEC (European Economic Community).

This group of countries is united economically, but when they become united religiously and politically as well, an "extremely strong" union will result. They will have "productive capacity nearly equaling (or surpassing) that of the United States."<sup>9</sup> Hal Lindsey and others have done a good job of showing the connection between the EEC and: (1) the ten horns of Daniel 2:31-35, (2) the ten horns of Daniel 7:7 and, (3) the ten horns of Revelation 13:1 and 17:3-16.<sup>10</sup> Therefore, I will not say more about it.

The EEC summation: It is a world power of awesome potential, nearly but not completely, solidified. When "Antichrist", the political leader, and "False Prophet", the religious leader, come to power (Revelation 13), we will see the EEC take over the world. The demise of the U.S. and the C.I.S. is all that prevents it. If a nuclear exchange between the U.S. and C.I.S. cancelled each other, that would leave the E.E.C. in a world dominating position.

Let's sum up our thoughts. When we look at the world powers today, evaluate their national symbols and compare them with Daniel Seven, we have a definite match. Thus we can readily believe modern empires apply to Daniel Seven. In the face of such evidence, how can anyone not see the USA in Biblical prophecy?

## 5. The End Time Bear

The fifth reason why Daniel Chapter Seven is describing modern contemporary nations is the C.I.S., a current world power, whose national symbol is the "Bear", is known from *other* scripture to be involved in end time events.

Quoting Halley in his commentary concerning Ezekiel Chapters 38 and 39,

"Whatever may be the exact identification of these peoples, (Magog, Meshech, Tubal, Gomer and Rosh) Ezekiel speaks of

---

8. "Daniel - The Key to Prophetic Revelation", p. 162.

9. "US News and World Report", June 11, 1979

10. "The Late Great Planet Earth", pp.83-86, Hal Lindsey, New York, N.Y.: Bantam Books, 1970.

them as dwelling in 'the uttermost parts of the north' (38:6, 15; 39:2), and there can be little doubt that he means nations beyond the Caucasus (mountains). A glance at the map makes it plain that he has in mind that part of the world known as Russia.”<sup>11</sup>

From the rest of Chapters 38 and 39, we see evidence of Magog and its associates invading Israel and being destroyed. Since no similar circumstances have occurred in history, we can conclude that it is yet future and therefore, a part of end time events.

Just look at the evidence! It is known from Ezekiel 38 and 39 that Russia is involved in end time events. Russia’s national symbol is the “Bear”. A “Bear” is symbolized in Daniel 7:5 and Revelation 13. How can anybody deny this truth? How can they say modern nation-empires are not involved?

## **6. Revelation 13 Parallel to Daniel 7**

There is yet another reason this interpretation applies to Daniel Seven. Let's look at another scripture, known to be prophetic, having similar descriptions and interpretation, that shows Daniel 7:1-6 to be current history.

The descriptions, "Lion", "Bear", and "Leopard" of Daniel Chapter Seven also appear as part of the descriptions of the beast in Revelation 13:1-2.

“And he stood on the sand of the seashore. ‘And I saw a beast coming up out of the sea, having ten horns and seven heads, and on his horns were seven diadems, and on his heads were blasphemous names.

‘And the beast which I saw was like a leopard, and his feet were like those of a bear, and his mouth like the mouth of a lion. And the dragon gave him his power and his throne and great authority.’”

We also know the fourth beast of Daniel Chapter Seven and the beast of Revelation 13 are one and the same; as is pointed out by Strauss, Halley, Walvoord and others.<sup>12</sup> It appears clear in the scripture and confirmed by competent scholarship, that the beast of Revelation 13 and the Fourth

---

11. "Halley's Bible Handbook", p.333, Henry H. Halley, Grand Rapids, Michigan: Cindering Publishing House, 1965.

Beast of Daniel Seven are the same beast.

This means conservative expositors agree that the fourth beast of Daniel 7:1-7 is an end time player. But, they won't admit that the other three beasts are end time players. I have just shown, and many agree, that Russia is an end time player! This sure looks like denial which covers the pride of being wrong.

The empire of Revelation 13 is composed, at least partially, of nations represented by a lion, bear and leopard. And, any empire that is composed of other nations, must be contemporaries of those nations. If the Lion, Bear and Leopard of Revelation 13 are contemporaries of the beast of Revelation 13, and, it is the same beast as the Fourth Beast of Daniel Seven; Therefore, the Lion, Bear and Leopard of Revelation 13 must be contemporaries of the Fourth Beast of Daniel Chapter Seven!

This logic sequence reveals four important conclusions: (1) The "Lion", "Bear", and "Leopard" descriptions apply, at least, to the end time kingdoms. (2) Revelation 13 describes absorbed nations from *after* the fact, and Daniel Chapter Seven describes absorbed nations from *before* the fact. (3) The first three beasts of Daniel Chapter Seven are the ones Absorbed/trampled, and therefore is the identity of the "remainder" mentioned in verses Seven and 19. (4) The kingdoms of the "Lion", "Bear" and "Leopard" of Daniel Chapter Seven must be contemporaries of the Fourth Beast.

Because Daniel Chapter Seven and Revelation 13 describe the same beasts, we can conclude they are modern contemporary nations. These observations by themselves bring a strong case but when coupled with the rest of the evidence this interpretation becomes highly probable.

## 7. Conservative Expositors View

The conservative expositor interpretation of Daniel 7:1-7 suggests the first three beasts are three ancient empires. They are Babylon, Medo-Persia, and Greece. The fourth empire consists of an earlier phase; the old

---

12. "The Prophecies of Daniel", Lehman Strauss, Neptune, N.J.: Lissajou Brothers, 1969, p.211; "Halley's Bible Handbook", p.346; "Daniel - Key to Prophetic Revelation", p.175.



Roman empire, and a later phase which is the revived Roman empire.

### **The Three Contextual Possibilities**

Daniel, in Chapter Seven appears to describe four world class empires. The fourth empire appears to crush the other three literally because that is what it says. The fourth empire controls all the others when Jesus returns.

The question is: when and how does the fourth beast crush the other three? If we accept the premise that these empires can be found in space and time; somewhere between the beginnings of Babylon and the second coming of Christ, there seems to be just three practical, contextual possible interpretations.

Each empire is either: (1) ancient historic, an empire which existed before or at Christ's time; (2) current historic, an empire which exists now, in the 21st century; (3) prophetic, an empire which does not exist now but will exist in the future; or some combination of the above. In any case, the fourth beast must exist at the future time when Jesus returns to set up His eternal kingdom because of the "rock" crushing the statue.

(1) The first possibility. One or more of the first three empires is ancient historic, and the fourth is prophetic; such that the fourth empire tramples the vestiges of the first three. Vestiges are what is left over after the original empire is defeated. This option suggests the prophetic fourth beast tramples modern countries which originally came from the first three ancient kingdoms.

(2) The second possibility. The first three kingdom/empires are ancient historic and the fourth is divided into an earlier phase that is ancient historic, and a later phase that is prophetic; the Fundamental Conservative Position. These people believe the later Phase of the fourth beast tramples everyone around them but the first three beasts (Lion/Eagle, Bear, etc.) are not the **modern** nations trampled. The earlier phase of the fourth beast tramples countries which once were Babylon (Iran), Medo-Persia, and Greece. This means they are forced into the position of saying the modern countries which I say represent the "Lion/Eagle," "Bear," and "Leopard" are not involved in scripture! If they say otherwise, they agree with me.

(3) The third possibility. The first three kingdoms are current historic and the fourth prophetic such that the fourth tramples the others

directly and literally. All four are contemporaries of each other.

All these interpretations center around the issue of concurrent existence. Do all four beasts exist concurrently (at the same time) or do they succeed one-another? I have shown above that the ancient empires all succeeded one another. I guess the best we can do is to look at the facts and you discern for yourself if truth exists herein. A friend once quipped, "That which is most believable is that which is most consistent with the facts." Just remember, if these three points of view are indeed all the contextual possibilities, then one of them must be the truth. Thus whichever best fits the facts is probably the truth. Let's look at possibility one, the vestiges option.

### **Possibility 1, Vestiges?**

As you will remember, Possibility One maintains that one or more of the first three kingdoms is ancient historic and the fourth is prophetic such that the fourth empire tramples the vestiges of the first three, but not the three themselves. They realize the fourth beast tramples somebody at the end time but that it can't be the ancient historic kingdoms. These folks get around the issue of concurrent existence by substituting a modern vestige of an ancient empire to get around the 2000 year span they see between the third and fourth beasts.

For this view to be valid, they would have to show how today's world powers are vestiges of Babylon, Medo-Persia and Greece to provide candidates that could be trampled; or believe the ancient kingdoms could be world powers again someday; and, believe that God has ignored the current contemporary world powers.

We know that God has not ignored current contemporary powers because Russia is mentioned in Ezekiel Chapters 38 and 39. Thus there is a Biblical precedent for mentioning other contemporary world powers.

With respect to the vestiges idea, could someone show how the current contemporary powers are vestiges of the ancient empires? Could the vestiges of the ancient world powers (Syria, Iran, Iraq, Greece, and Italy) become world powers again? Maybe, but there are three reasons why Babylon, Medo-Persia and Greece are *not* present world power antecedents.

(1) They are not world class powers but the language of the text and other scripture demands they be;

(2) It is not likely these ancient countries could become world class powers again because it is known to be near the time of the end;

(3) The C.I.S. (USSR) has never been a part of the four empires but it is involved in end time events per other scripture.

To accept this "Vestiges" option is to believe that God would focus on the remnant of the ancient kingdoms when the U.S., Russia and others are many times more powerful. This notion is inconsistent with the following Chapter Two strength model.

We see a definite increase in the strength of each empire as the Second Coming approaches. John Walvoord, President of Dallas Theological Seminary, comments concerning the poly metallic statue of Chapter Two:

"The descending value of the metals, however, permits their ascending strength, which suggests increased military might during the times of the Gentiles, leading to the final world conflict of Revelation 16 and 19 to which Daniel refers (11:36-45)."<sup>13</sup>

Not only is the vestige idea contrary to the strength model, but it doesn't seem logical for God to ignore more powerful and significant empires, namely the USA, CIS, and EEC, in favor of ancient empires that have little influence in the future consummation. For these reasons, the truth must lie in some other alternative.

## **Possibility 2, The Accepted Fundamental Conservative Position**

John Walvoord, in the introduction of his commentary on Daniel Chapter Seven, states Possibility No.2; the accepted fundamental conservative position.

"In the interpretation of biblical prophecy, the seventh chapter of Daniel occupies a unique place. As interpreted by conservative expositors, the vision of Daniel provides the most comprehensive and detailed prophecy of future events to be found anywhere in the old Testament. Although its interpretation has varied widely, conservative scholars are generally agreed, with

---

13. "Daniel - The Key to Prophetic Revelation", p.66.

few exceptions, that Daniel traces the course of four great world empires, namely, Babylon, Medo-Persia, Greece and Rome, concluding in climax of world history in the second coming of Jesus Christ and the inauguration of the external kingdom of God, represented as a fifth and final kingdom which is from heaven.”

If this is the case, what nation-empires are represented by the gold, silver, and bronze which gets crushed by Jesus at the end time? They have no answer for that important point. Continuing the quote:

“Interpreted in this way, the chapter forms a major outline of future events to which additional details are given later in the book of Daniel and in the New Testament, especially in the Revelation. Such a panorama of future events is of great importance to the student of prophecy, as it provides a broad outline to which all other prophetic events may be related. Conservative interpreters are agreed that this is genuine prophecy, that it is futuristic, that is, related to future events from Daniel's point of view, and that its culmination is the kingdom which Christ brings.”<sup>14</sup>

This view is widely held by many conservative scholars today including Lehman Strauss,<sup>15</sup> Tim LaHaye,<sup>16</sup> Clarence Larkin,<sup>17</sup> and H.A. Ironside.<sup>18</sup> Their position, as I understand it, is the four beasts of Daniel, Chapter Seven correspond to the four parts of the statue of Chapter Two, when interpreted, corresponds to the empires of Babylon, Medo-Persia, Greece and Rome. Rome is divided into an earlier phase that conquers Greece and a later phase that produces the end time Antichrist. Then Jesus comes and destroys the kingdom of the Antichrist. But what about the nation-empires represented by the gold, silver, and bronze at the 2nd coming? Walvoord does not comment. Why?

Four beasts come up out of the sea; the fourth tramples the other three and Jesus comes back to take over the world. It seems that the similarity of the two chapters (2 and 7) has led scholars to the idea that the

---

14. .Ibid, p.145:

15. "The Prophecies of Daniel", pp.206-210.

16. "The Beginning of the End", p.157, Tim LaHaye, Wheaton Ill.: Dental House Publishers, 1972.

17. "The Book of Daniel", p.121, Clarence Larkin, Philadelphia, P.A.: Clarence Larkin, Est., 1929.

18. "Lectures on Daniel the Prophet", pp.125-129, H.A. Ironside, Neptune, N.J.: Lissajou Brothers, 1920.

two chapters mean the same thing but are just expressed in different terms. The lack of a better explanation probably also plays a part in shaping previous interpretations. However, in the next section I will point out some differences in the two chapter's facts, that **demand** a different explanation.

## **Accepted Fundamental Conservative Position Problems**

The problems seem to center around the issue of concurrent existence.

Daniel 7:7 says about the fourth beast:

“After this I kept looking in the night visions, and behold, a fourth beast, dreadful and terrifying and extremely strong; and it had large iron teeth. It devoured and crushed and trampled down the remainder with its feet; and it was different from all the beasts that were before it, and it had ten horns.”

Who is the remainder? From the context of verse 7, there is no doubt that the remainder is the aforementioned “Lion/Eagle,” “Bear,” and “Leopard?”

This verse is very specific about the fourth beast devouring some nations around it; crushing some nations around it; and trampling some nations around it. Who are these nations? From Revelation 13, we discern that the “Lion,” the “Bear,” and the “Leopard” are the nations subdued; among others. That means in order to devour, crush and trample the remainder, the “Lion,” “Bear,” and “Leopard” must be contemporary nation-empires and not ancient nation-empires. In other words, the “Lion,” “Bear,” and “Leopard” cannot be ancient empires but must be contemporary with the fourth beast. If you don’t agree, you are disagreeing with what the Word of God clearly says in Verse Seven.

To say the fourth beast tramples ancient empires; is equivalent to saying the USA, Russia, and the Arabs are of no consequence in the modern world political situation. To take that position seems ridiculous in view of the available light on this subject.

The second problem shows up in Chapter Two where Daniel relates the vision of the poly metallic statue. It had a head of Gold, chest and arms of silver, belly and thighs of bronze, legs of iron, and feet of iron and clay. As the King gazed at the statue, a rock came flying through the air and hit the statue on its feet. The statue collapsed and was crushed to

powder. The powder was blown away by the wind after which the rock became like a mountain and filled the whole earth. Concerning the interpretation, verses 34-35 read:

"You (Nebuchadnezzar) continued looking until a stone (Jesus) was cut without hands, and it struck the statue on its feet of iron and clay, and crushed them. Then the iron, the clay, the bronze, the silver and the gold were crushed *all at the same time*, (emphasis mine) and became like chaff from the summer threshing floors; and the wind carried them away so that not a trace of them was found."

These verses demand concurrent existence of the Gold, Silver, Bronze, and Iron/Clay (four empires) at the coming of Jesus unless you spiritualize the expression "at the same time".

Accepted conservative expositors are forced to spiritualize this expression in order to support the notion that the gold, silver, etc. only represent ancient empires. If they were to take the expression literally, they would have to show how Nebuchadnezzar (the head of gold; verse 38) could exist at the Second Coming or admit the gold, silver, etc., has other figurative meaning. They choose to spiritualize the words "...at the same time,..." This is a problem because verse 45 prevents spiritualization.

"Inasmuch as you saw that a stone was cut out of the mountain without hands and that it crushed the iron, the bronze, the clay, the silver, and the gold, the great God has made known to the king what will take place in the future; so the dream is true, and its interpretation is trustworthy."

To me, the Holy Spirit is reiterating that the events are literal and it is the "Rock" that crushes the gold, silver, etc.

The rules of interpretation say you should not spiritualize unless it is necessary to make sense. Is it necessary? It would be appropriate to enter here the conservative expositors comments but Ironside, DeHaan, Walvoord, Newell and Strauss were silent on this point. Why do they ignore such a blatant point? Are they in denial?

I believe it is not necessary to spiritualize these verses because there is an alternative view, Possibility Three, that permits a literal interpretation.

If we interpret the gold, silver, etc. to be figurative, as other conser-

vative expositors do, but not limit the meaning to just Babylon, Medo-Persia, etc.; then these verses become a type or model of two sets of events future to the visions of Daniel. I mentioned them at the beginning.

### **Possibility 3, Similar Empires but not Identical**

As Walvoord brought out, conservative expositors view Chapter Seven as a repeat of Chapter Two. They would say Chapter Seven means the same as Chapter Two but uses different symbols. I would like to suggest that they are similar but not identical. If we can show they are similar but not identical, then it is easy to believe the two chapters may each mean something different.

In Chapter Two, conservative expositors view the first three statue sections (gold, silver and bronze) as Babylon, Medo-Persia and Greece. They view the legs of iron as ancient Rome, and the feet of iron/clay as the revived Roman empire.

In Chapter Seven, they view the first three beasts (Lion/Eagle, Bear, and Leopard) as Babylon, Medo-Persia and Greece. The fourth beast as future to 2011.

I do not view the first three beasts as ancient historic. However, I see the fourth beast of Chapter Seven as existing presently.<sup>19</sup> Now that we have the facts summarized, let's look at the differences between the two chapters.

In Chapter Two, we all agree that the legs of iron and the feet of iron/clay have a connection. The legs of iron represent the old Roman empire, and the feet of iron and clay symbolize a future revived Roman empire. Thus we interpret these verses to imply a long span of time between the old Roman empire and the revived Roman empire nearly 2000 years later.

In Chapter Seven, we see no such implication. There are simply four beasts representing four empires. The text makes no mention of a divided or split fourth beast. Thus the two chapters are similar but not identical. The Chapter Seven text implies, if anything, just the opposite. It reads as if all four empires exist concurrently. **This is a fatal flaw**

---

19. It was future when Walvoord wrote but is on the world scene now in the form of the ten nation European Economic Community (EEC).

**which demands a different Chapter seven interpretation.**

In Chapter Two, the interpretation of the poly metallic statue begins with Babylon and ends with Jesus at the Second Coming. In the dream interpretation, only the identity of the first and last empires are named specifically: Babylon first (verse 38) and the reign of Jesus Christ last (verse 45). The identity of the other empires has been inferred from the context.

I believe conservative expositors are justified in seeing Medo-Persia, Greece and Rome in these verses but since the empires are not named specifically and the reign of Jesus (end times) is in view, they are not justified in limiting the interpretation to just ancient empires. Because, Chapter Two may be a “type;” of which, Chapter Seven is a fulfillment. See the page 17 chart.

The four beasts of Daniel Seven are not ancient empires. The four beasts are modern empires ending with the Second Coming. If the fourth beast, as Walvoord says, is 21st century, then the other three beasts must be 21st century.

In the conservative expositors view, the old Roman empire took over Greece, and Greece took over Medo-Persia, and Medo-Persia took over Babylon. Who does the Revived Roman empire take over? Don't you dare say the USA, CIS, and Arabs because that is my view! That would be intellectually dishonest.

## **Increased Strength**

It is inconceivable that God could view the modern empires as insignificant compared to the ancient empires? Is there any doubt that the U.S. is stronger, of more Godly heritage, or more protective of Israel than the ancient empires (those things that God would say is important)? Could anyone show how and why the ancient kingdoms could be more significant than the modern empires? I doubt it.

Now is the climax of history; the most important time of any age. Because Jesus is about to claim His throne in power and great glory! He will triumph over the strongest of the strong of all time. Let's look at the significance question.

Daniel 2:32-33 points out the problem. Looking at Nebuchadnezzar's statue, we see the head of gold, arms and chest of silver, belly and thighs of bronze, legs of iron and clay. This series of materials suggests a logi-



cal sequence. Notice the decreasing value and specific gravity, while at the same time, there is an increase in the strength of the metals. As Walvoord said before:

"The descending value of the metals, however, permits their ascending strength, which suggests increased military might during the times of the Gentiles, leading to the final world conflict of Revelation 16 and 19 to which Daniel refers (11:36-45)."<sup>20</sup> It appears we agree that this scripture is suggesting the modern empires are stronger than the ancient kingdoms.

This means Walvoord is admitting the modern nations are much stronger than the ancient empires.

How about our relationships? Could Israel survive against the Russian "Bear", humanly speaking, if the United States "Eagle" did not protect her? Hardly! If the U.S. had not agreed to protect Israel, Russia would have been there long ago. Thus God would have had to intervene long ago. Doesn't most of the worlds missionary funds come from the U.S.? Isn't the Russian "Bear" known, from Ezekiel 38 and 39, to be significant in end time events? Someone will have to show me why the modern empires are less significant than the ancient empires. Because that idea simply does not fit the Biblical or scientific facts.

## Different National Symbols

Conservative expositors suggest that the national symbols of the Chapter Seven empires (lion/Eagle, Bear and Leopard) point toward the ancient empires as the subjects of that chapter. That idea seems to conflict with Daniel, Chapter Eight.

The national symbols given for Medo-Persia and Greece in Chapter Eight are **not** the same national symbols given in Chapter Seven to represent the nations depicted there. This means either God has assigned two national symbol/animal designations to one empire in two different scripture references, or the national symbols represent two different empires or nations. Chapter Eight, Verse 20, defines the "Ram" symbol as representing Medo-Persia. Historically, the image of a ram's head was stamped onto the coins of the empire, and they were used on the head

---

20. Ibid p.66.

dress of the Persian Emperors.<sup>21</sup> It was their national symbol.

By contrast, the second beast of Chapter Seven, the Bear, is not very close in likeness, character or actions to that of a ram. There seems to be no logical connection, whatsoever, between the Bear and the Ram.

When God wanted to show that an empire was made up of several other nations, He used the name of more than one animal to describe it. For example; the fourth beast of Daniel Seven, and its parallel passage, the beast of Revelation 13,<sup>22</sup> have the animals named in the same verses. They are the Lion, Bear and Leopard. This is an indication that the Lion, Bear and Leopard nations became a part of the fourth beast empire. Thus more than one animal name per empire probably does not apply to Medo-Persia and Greece as individual national entities.

Likewise Greece, defined in Chapter Eight as a "goat", is the third world empire in Chapter Two. Could it also have a twin designation (Leopard) very diverse from the other? A better explanation is different symbols; different empires.

## **A Summary and Conclusions**

I have shown that King Nebuchadnezzar cannot be a representation of the head of gold at the 2nd coming. He died four years before Daniel prophesied there would be four future kings. If he is not the head of gold at the 2nd coming; who is? Conservative expositors have no answer. This is a fatal flaw.

Daniel Chapter Seven speaks of the fourth beast trampling the other three beasts. If the fourth tramples the other three, then the three must, by the laws of physics, be contemporaries of the fourth beast. That means ancient empires are not involved except in "type." This is a fatal flaw.

We have looked at verses implying concurrent existence (2:34-35, 45) and verses implying succeeding empires (2:38-40) in the same chapter. This means there must be two sets of empires that fulfill the Chapter Two statue picture in its entirety. Because the conservative expositors theory does not accommodate that fact, it is a fatal flaw, and the theory must be discarded.

---

21. "The Prophecies of Daniel", pp.235-236.

22. "Ibid", p.211.

The popular conservative view suggests Daniel 7 is a repeat of Chap. 2. However, I have shown that Chap. 7 is different, in that there is no implication of a split fourth beast as in Chap. 2. And, only the empires of Babylon and Jesus are specifically named. This means the identity of all the other empires are implied from the context. This leaves their identities open to accommodate the "type" picture I described.

The conservative expositors view does not adequately deal with how a modern 4th beast (empire) of Daniel 7 can crush and trample supposed ancient (first three) Beast/empires. Nor do they suggest who actually gets crushed in the 21st century. If not modern empires, then who?

No scholar that I know of suggests reasons for God ignoring modern world class empires in favor of politically insignificant ancient empires at the Second Coming. We have seen that the ancient empires interpretation violates the ascending strength model of the Chap. 2 statue vision.

If the Lion/Eagle is really Babylon, as conservative expositors say, Then how can Nebuchadnezzar, who was dead at the time Chap. 7 was written, be one of four future kings (7:17)? That is impossible!

If the Bear and Leopard of Chap. 7 represent Medo-Persia and Greece, and Medo-Persia and Greece are specifically represented as a Ram and Goat in Chap. 8, then why has God given each of those countries *two* national symbols? That appears to be inconsistent. A better explanation is different symbols; different empires.

Any one of these fatal flaw reasons are enough to doubt the fundamental conservative interpretation of these verses. But all the reasons taken together form a foundation for discarding the conservative expositors view. Therefore, I suggest the first three kingdoms are the U.S., C.I.S., Arab-Africa alliance and the fourth the E.E.C., not politically solidified yet. And that the fourth kingdom, the EEC, will trample the others directly and literally.

I have shown that the four beasts of Daniel Chapter Seven are the same as the composite beast of Revelation 13. Since we know the beast of Revelation 13 is future, that means the four beasts of Daniel Chapter Seven must be modern and contemporary.

It is widely believed that the Russian "Bear", mentioned in Ezekiel, has a part in end time events. I am also saying they have a part and a further description of their part can be found in Revelation 13. The blatant fact is the Russian "Bear" in Asia matches the Revelation "Bear" which matches the Daniel Seven "Bear". These facts should give you a basis to

believe this interpretation and discard your old one.

When we view the Gold, Silver, etc. of Daniel Two as types, with two fulfillments in history, all the scriptural passages involved make more sense. We can see Daniel Chapter Eight as the fulfillment in ancient history and Daniel Chapter Seven as the fulfillment in modern history. These smoothly integrate with the outline of Jesus establishing His fifth and final kingdom (over the Gold, Silver, Bronze and Iron) on planet earth.

We are therefore, witnessing the concluding events of history as described in Daniel Chapters Two and Seven, Revelation 13 and other passages.

If you would like more information on end time events, please read my website book at:

**[www.soulsurvival.info](http://www.soulsurvival.info)**